



3,000-6,500 lb Capacity LP Gas Cushion Tire Forklift Trucks



These N-Generation cushion tire forklift trucks are equipped with several technologically advanced features, including envirO₂ engines™ that exceed the latest U.S. Environmental Protection Agency (EPA) emissions requirements. For peace of mind, all models are equipped with the Integrated Presence System (IPS), which temporarily disengages both the drive and the hydraulic functions of the truck in the event the operator leaves the normal operating position. With seven models to choose from, Mitsubishi Forklift Trucks offers the right truck for your material handling requirements.



Specifications

CHARACTERISTICS			FGC15N		FGC			
1	Capacity	at rated load center	lb	kg	3,000	1,500	3,500	
2		at load center-distance	in	mm	24	500	24	
3	Power	diesel, gasoline, lp gas, electric			LP gas		LP	
4	Tire type	cushion or pneumatic			cushion		cushion	
5	Wheels (x = driven)	number front / rear			2x / 2		2x / 2	
DIMENSIONS								
10	Lift	maximum fork height with rated load	in	mm	162	4,120	147	
11	Lift with standard two-stage mast	maximum fork height (top of forks)	in	mm	131	3,325	131	
12		free fork height	in	mm	4.5	115	4.5	
13	Forks	thickness x length x width	in	mm	1.4 x 42 x 4.0	35 x 1,070 x 100	1.4 x 42 x 4.0	
	Fork spacing	out-to-out minimum / maximum	in	mm	7.85 / 32.25	200 / 820	7.85 / 32.25	
14	Tilt	forward / backward	deg		5° / 10°		5° / 10°	
15	Overall dimensions	length to fork face	in	mm	82.0	2,085	83.2	
16		width	with standard tires	in	mm	38.2	970	38.2
			with standard tires, wide-stance	in	mm	39.2	995	39.2
			with standard tires, wide-axle	in	mm	N/A	N/A	N/A
17		height	mast lowered	in	mm	82.9	2,105	82.9
18			seat height	in	mm	42	1,067	42
19			top of overhead guard	in	mm	81.1	2,060	81.1
20	mast extended		in	mm	179.2	4,550	179.2	
21	Minimum outside turning radius		in	mm	70.0	1,777	71.2	
22	Load moment constant		in	mm	15.3	390	15.3	
23	Minimum aisle - 90° stack - zero clearance w/out load		in	mm	89.3	2,267	90.5	
PERFORMANCE								
40	Speeds	travel speed loaded / empty	mph	km/h	9.8 / 10.2	15.8 / 16.4	9.8 / 10.2	
41		lift speed loaded / empty	fpm	mm/s	121 / 125	617 / 633	121 / 125	
42		lowering speed loaded / empty	fpm	mm/s	99 / 99	500 / 500	99 / 99	
43	Draw bar pull	loaded at 1 mph (1.6 kph)	lb	N	3,760	16,715	3,745	
		loaded maximum	lb	N	4,245	18,880	4,230	
44	Gradeability	loaded at 1 mph (1.6 kph)	%		37		37	
		maximum loaded / empty	%		43 / 20		40 / 20	
WEIGHT								
50	Empty		lb	kg	6,067	2,752	6,449	
51	Axle load	without load front / rear	lb	kg	2,315 / 3,752	1,050 / 1,702	2,185 / 4,264	
		with load front	lb	kg	7,831	3,552	8,618	
CHASSIS								
60	Tire size	front, standard	in		18 x 6 x 12½		18 x 6 x 12½	
61		rear	in		14 x 5 x 10		14 x 5 x 10	
62	Wheel base		in	mm	46.9	1,190	46.9	
63	Tread width	front, standard tires	in	mm	32.2	820	32.2	
		front, wide-stance tires	in	mm	33.2	845	33.2	
		rear, standard tires	in	mm	31.8	810	31.8	
65	Ground clearance	at lowest point of mast	in	mm	2.9	75.0	2.9	
		at center of wheel base	in	mm	4.5	116	4.5	
67	Brakes	service	type		foot, hydraulic		foot, hydraulic	
68		parking	type		hand, mechanical		hand, mechanical	
POWERTRAIN								
80	Engine	model			K21		K21	
81		continuous output (s.a.e. gross)	HP	kW	50	37.4	50	
			at rpm		2,400		2,400	
82		maximum torque (s.a.e. gross)	lb-ft	Nm/rpm	111	151	111	
			at rpm		2,000		2,000	
83	cylinder displacement	cu in	L	126	2.1	126		
84	Transmission	type		powershift		powershift		
85		number of speeds forward / reverse		1 / 1		1 / 1		
86	Battery	volts		12		12		
HYDRAULICS								
87	Relief pressure	for attachments at auxiliary valve	psi	bar	2,250	158	2,250	
89	Hydraulic flow	for attachments at auxiliary valve	gpm	lpm	19.0	72.0	19.0	

18N	FGC20CN		FGC20N		FGC25N		FGC30N		FGC33N	
1,800	4,000	2,000	4,000	2,000	5,000	2,500	6,000	3,000	6,500	3,300
500	24	500	24	500	24	500	24	500	24	500
gas	LP gas		LP gas		LP gas		LP gas		LP gas	
tion	cushion		cushion		cushion		cushion		cushion	
/2	2x / 2		2x / 2		2x / 2		2x / 2		2x / 2	
3,750	N/A	N/A	170	4,320	170	4,320	186	4,725	186	4,725
3,325	131	3,330	131	3,340	131	3,345	130	3,310	131	3,340
115	4.7	120	5.1	130	5.3	135	5.3	135	5.3	135
35 x 1,070 x 100	1.6 x 42 x 4.0	35 x 1,070 x 100	1.6 x 42 x 3.9	40 x 1,070 x 100	1.6 x 42 x 3.9	45 x 1,070 x 100	1.8 x 42 x 4.9	45 x 1,070 x 125	1.8 x 42 x 4.9	45 x 1,070 x 125
200 / 820	7.85 / 32.25	200 / 820	7.8 / 36.0	200 / 920	7.8 / 36	200 / 920	8.0 / 38	200 / 960	8.0 / 38	200 / 960
10°	5° / 10°		5° / 9°		5° / 9°		5° / 6°		5° / 6°	
2,115	85.6	2,175	90.5	2,295	93.0	2,360	96.5	2,450	97.5	2,475
970	40.2	1,020	42.0	1,065	42.0	1,065	44.0	1,115	44.0	1,115
995	N/A	N/A	44.5	1,130	44.5	1,130	45.5	1,155	45.5	1,155
N/A	N/A	N/A	N/A	N/A	N/A	N/A	N/A	N/A	N/A	N/A
2,105	82.9	2,105	83.5	2,110	83.5	2,110	83.5	2,110	88.0	2,230
1,067	42	1,067	41.7	1,059	41.7	1,059	41.7	1,059	41.7	1,059
2,060	81.1	2,060	82.0	2,075	82.0	2,075	82.0	2,075	82.0	2,075
4,550	179.2	4,550	180	4,570	180	4,570	179	4,540	180	4,570
1,810	72.8	1,850	77.5	1,965	79.5	2,020	82.5	2,095	83.5	2,125
390	15.9	405	16.3	415	16.5	420	17.2	435	17.2	435
2,300	92.7	2,355	97.6	2,480	100.0	2,540	104.5	2,655	105.7	2,685
15.8 / 16.4	9.8 / 10.2	15.7 / 16.4	11.0 / 11.5	17.5 / 18.0	11.0 / 11.5	17.5 / 18.0	10.0 / 10.5	16.5 / 17.0	10.0 / 10.5	16.5 / 17.0
617 / 633	121 / 125	617 / 633	115 / 115	580 / 590	115 / 115	580 / 590	105 / 105	530 / 540	105 / 105	530 / 540
500 / 500	99 / 99	500 / 500	99 / 99	500 / 500	99 / 99	500 / 500	98 / 99	500 / 500	98 / 99	500 / 500
16,640	3,705	16,475	3,750	16,700	3,725	16,500	4,500	20,000	4,500	19,900
18,815	4,195	18,645	4,250	18,900	4,225	18,800	5,100	22,600	5,075	22,600
2	28		35		29.4		30.4		28.3	
18	35 / 18		40.5 / 27.7		33.9 / 22.8		34.8 / 19.6		28.3 / 18.4	
2,925	7,000	3,180	7,360	3,338	8,157	3,700	9,480	4,300	9,938	4,508
991 / 1,934	2,075 / 4,935	940 / 2,238	3,050 / 4,310	1,384 / 1,954	2,833 / 5,324	1,285 / 2,415	2,897 / 6,583	1,314 / 2,986	2,875 / 7,064	1,304 / 3,204
3,909	9,482	4,300	9,975	4,525	11,488	5,211	13,378	6,068	14,229	6,454
x 12½	18 x 7 x 12½		21 x 7 x 15		21 x 7 x 15		21 x 8 x 15		21 x 8 x 15	
5 x 10	14 x 5 x 10		16 x 6 x 10½		16 x 6 x 10½		16 x 6 x 10½		16 x 6 x 10½	
1,190	46.9	1,190	55.0	1,400	55.0	1,400	55.0	1,400	55.0	1,400
820	33.2	845	35.0	890	35.0	886.4	36.0	911.8	36.0	911.8
845	N/A	N/A	37.5	950	37.5	950	37.5	952	37.5	952
810	31.8	810	35	890	35.0	890	35.0	890	35.0	890
75.0	2.9	75.0	3.1	80.0	3.1	80.0	3.1	80.0	3.1	80.0
116	4.5	116	5.4	139	5.4	139	5.4	139	5.4	139
hydraulic	foot, hydraulic		foot, hydraulic		foot, hydraulic		foot, hydraulic		foot, hydraulic	
mechanical	hand, mechanical		hand, mechanical		hand, mechanical		hand, mechanical		hand, mechanical	
21	K21		K21		K21		K25		K25	
37.4	50	37.4	55.0	41.0	55.0	41.0	63	46.9	63	46.9
100	2,400		2,700		2,700		2,700		2,700	
151	111	151	114	154	114	154	139	188	139	188
1000	2,000		2,000		2,000		1,600		1,600	
2.1	126	2.1	126	2.1	126	2.1	152	2.5	152	2.5
powershift	powershift		powershift		powershift		powershift		powershift	
1 / 1	1 / 1		1 / 1		1 / 1		1 / 1		1 / 1	
2	12		12		12		12		12	
158	2,250	158	2,250	158	2,250	158	2,250	158	2,250	158
72.0	19	72	21.4	81	23.5	89.1	23.5	89.1	23.5	89.1

Call-out numbers shown in the diagram below correspond to the first column of the specifications chart.

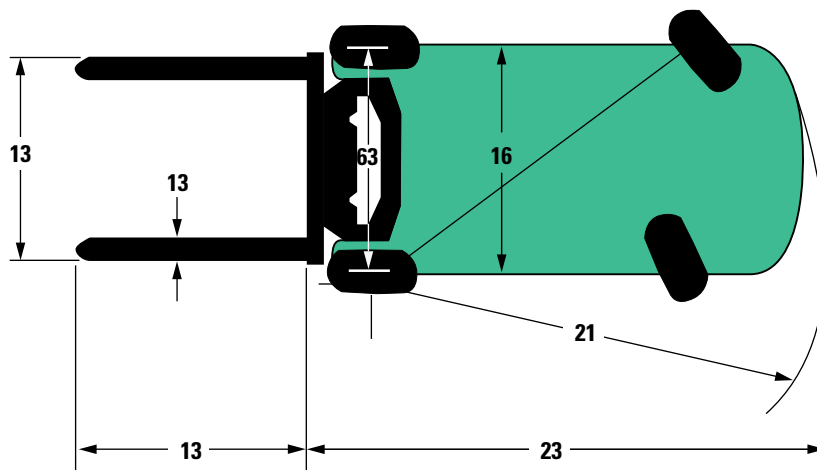
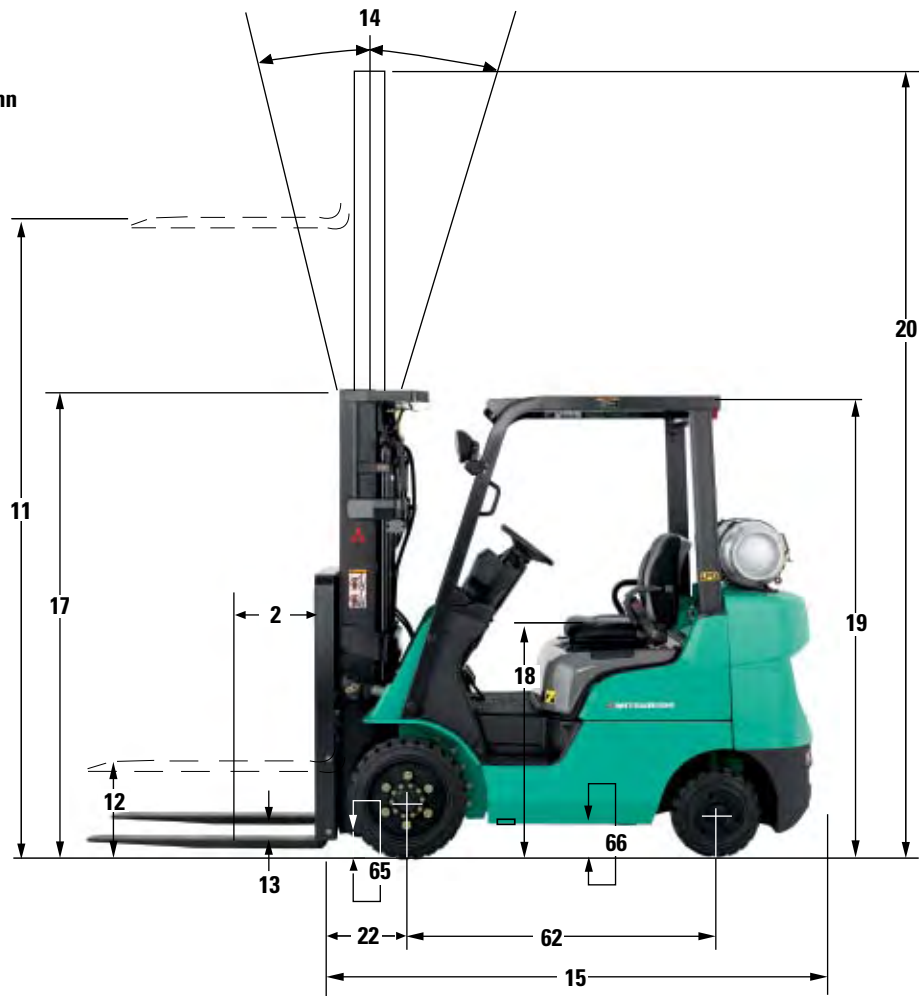

SAFETY STANDARDS

These trucks meet American National Standards Institute/ Industrial Truck Standards Development Foundation, ANSI/ITSDF B56.1. UL-Classified by Underwriters Laboratories, Inc., as to fire and electric shock hazard only; Type LP (standard), Type LPS (optional). Users should be aware of, and adhere to, applicable codes and regulations regarding operator training, use, operation and maintenance of powered industrial trucks, including:

- ANSI/ITSDF B56.1.
- NFPA 505, fire safety standard for powered industrial trucks -type designations, areas of use, maintenance and operation.
- Occupational Safety and Health Administration (OSHA) regulations that may apply.

Specifications, equipment, technical data, photos and illustrations based on information at time of printing and subject to change without notice. Some products may be shown with optional equipment.

NOTE: These specifications assume the use of drive axles, tires and tilt angles specified. Any modification to specifications, or any other combination of specifications made after the shipment of the truck, requires prior written approval from Mitsubishi Caterpillar Forklift America Inc. ("MCFA"). (See ANSI/ITSDF B56.1.) Also be advised that overall operating visibility may be affected by the mast configuration and mast options of your forklift truck. Therefore, you may need to add ancillary [auxiliary] devices or modify your operating practices. Consult your dealer for further information.

Standard Features

- EPA-compliant enviro₂ engines™
- Responsive drive-by-wire throttle control
- Throttle-body fuel injection
- LCD display panel with comprehensive read out features
- Memory tilt steering column
- Solid state distributor-less ignition system
- Platinum-tipped spark plugs
- Cross-flow, high pass through square fin radiator
- Integrated Presence System (IPS)
- Engine Protection System
- Electronic vehicle control featuring on-board diagnostics
- 500 hours service intervals

Drive System

The enviro₂ engines™ are highly efficient and exceed EPA requirements for HC, NO_x and CO emissions. All models are equipped with engines that are fuel-injected to bolster fuel economy and feature tamper resistant fuel management systems for lasting performance. These N-Generation models also feature drive-by-wire engine throttle control for enhanced fuel efficiency and improved emission levels while providing responsive acceleration.

Durability

From design to production these trucks were built to last. The frame construction features on the N-Generation are of a unitized design and provide exceptional rigidity and durability. The hydraulic control valves, transmission,

engine, radiator, muffler, steer axle and mast cylinders have all been rubber-mounted for extended life cycle performance. Sturdy steer and drive axles help protect the steer cylinder and drive components from foreign obstructions.

Operator Comfort And Protection

The operator compartment is designed to help your operators work as efficiently as possible. With the memory tilt steering column, operators can quickly return to their preferred steering-wheel position. An open step, conveniently located grab handle and seat hip restraint offer three secure brace points for easy entry and exit. To reduce load damage and improve operator security, these trucks include a mast and traveling interlock system. The Integrated Presence System (IPS) disconnects power to the drive motor and hydraulic functions when the operator leaves the normal operating position. In addition, IPS includes warning indicators for seat belt and parking brake.

Visibility

The N-Generation features a low-profile counterweight design providing your operator with good visibility over his shoulder, even with an LP tank on board. The front-to-back bar design of the overhead guard helps to provide a clear upward view. Forward visibility is enhanced by narrow mast channels and well-positioned cylinders, chain and hose routings. The incorporation of a square fork bar

design also optimizes forward visibility through the carriage to help your operator position materials with optimum efficiency.

Serviceability

Designed to keep you moving in dynamic, fast-paced environments, these trucks offer 500 hour service intervals and a comprehensive on-board diagnostic system that alerts the operator of potential problems early. All powertrain components are covered by a two-year/4000 hour limited warranty reducing the risk of a major, early hour expense. The result is a dramatic reduction in downtime and labor expense.



See For Yourself

- Mitsubishi is recognized for delivering value and the 500 hour service interval is just one example of how quality design and reliable components are incorporated to dramatically reduce routine maintenance costs over the life of the truck.
- Your cost of ownership is further reduced with a two-year/4000 hour limited powertrain warranty.
- Because productivity is so important to lowering costs, these trucks have been designed to maximize visibility, a major contributor to an operator's productivity. Compare the visibility from the operator's seat and take notice of the narrow mast channels, single direction overhead guard and low-profile counterweight design that promotes good visibility during reverse travel.
- A standard safety feature on this forklift is the exclusive Integrated Presence System (IPS) which temporarily disengages the drive and hydraulic functions should the operator leave the normal operating position.



Ready. Reliable. Right On The Money.

Manufactured with superior quality and exceptional value, Mitsubishi forklift trucks are supported by an extensive dealer and field support network. Dealer locations exist throughout North and South America, offering flexible financing options and product support.

Value And Support For The Long Haul

Our programs deliver value just like our forklifts. One example is our parts program, designed to be your single source for quality replacement parts — no matter what forklift brand you own. Another is the Master Protection® program which offers extended powertrain warranties for your Mitsubishi forklifts. Your Mitsubishi forklift truck dealer offers an extensive line of products and services including Master Maintenance® programs, which tailor service and maintenance to your specific applications. Your Mitsubishi forklift truck dealer can provide options and additional visual and audible warning devices aimed at your specific applications and requirements. Operator training programs are also available to help reduce the potential for product damage and personal injury.

**LP Gas Cushion Tire
3,000-6,500 lb Capacity**



**1-888-MIT-LIFT
www.mit-lift.com**