

MANISCOPIC

MLT 741

120 LSU Turbo

- Lift Capacity: 8,000 lb.
- Maximum Lift Height: 22 ft. 7 in.
- Maximum Forward Reach: 13 ft. 2 in.
- Perkins 123 HP Engine
- Torque Convertor
- Four Wheel Drive
- Three Steering Modes



Load Sensing Ultra

 **MANITOU**

MLT 741-120 LSU Turbo



Lift Capacity:

Maximum (24 in. load center)8,000 lb.
Break out force on bucket teeth
with tilting ram (ISO 8313)12,477 lb.



Lift Height:

Maximum lift height22 ft. 7 in.
Maximum forward reach13 ft. 2 in.
Times: unladen / loaded (in sec)

Lifting7.0/7.5
Lowering5.3/5.2
Boom extension8.2/9.0
Boom retraction6.2/6.0



Tires:

.....17.5LR24XM27



Forks:

Length48 in.
Thickness/width2.25 in. x 4 in.
Carriage rotation146°



Brakes:

.....Multidisc - hydraulically assisted on four wheels



Engine:

TypePerkins 1104C-44TA Turbo Diesel
Displacement4 cyl. 268 cu. in.
Power123 HP/90.5 kw
Maximum Torque320 ft.lb. at 1400 rpm
InjectionDirect
CoolingWater



Transmission:

TypeTorque Convertor
Electro-hydraulic reversing shift
Speeds forward/reverse4/4
Maximum travel speed21 mph



Hydraulics:

PumpPiston type
Flow3900 PSI - 40 gpm
Flow divider with priority to steering and braking



Capacities:

Cooling system4.9 gal.
Engine oil2.9 gal.
Transmission oil4 gal.
Hydraulic oil33 gal.
Fuel tank32 gal.



Specifications:

Weight (base unit)15,454 lb.
Turning radius (outside wheels)152 in.
Overall height91 in.
Overall width92 in.
Overall length (without forks)193 in.
Ground clearance17 in.
Maximum drawbar pull20,457 lbf.

LOAD CAPACITY CHART

CALCULATED WITH 48" CARRIAGE AND FORKS
(OPTIONAL ATTACHMENTS CAN DERATE THIS CHART)

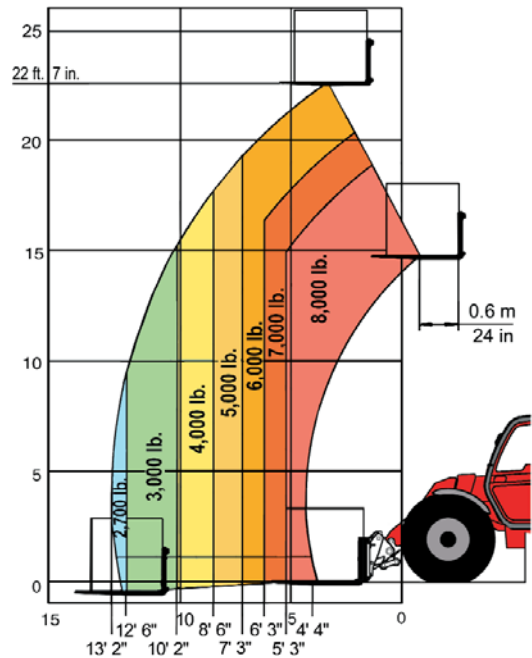

Capacities shown in pounds/feet are the maximum recommended load limits at the indicated extensions of the boom. Capacity ratings are based on a 48" homogeneous cube and are in accordance with ANSI/ASME B56.6 stability standards. Capacity reductions must be made for extended load centers and when used with various other attachments, contact MANITOU NORTH AMERICA, INC.

DIMENSIONS:

A48 L2
B111 N68
C48 O5
C₁51 P₂38°
D193 P₃53°
D₁196 R143
D₂169 S303
E241 T143
F74 U₁91
F₁74 U₂100
G18 V197
G₁17 V₁54
G₂17 V₂152
I34 W92
J34 Y12°
K66 Z134°

STANDARD EQUIPMENT:

- Enclosed Cab
- Hydraulic Power Steering
- Three Steering Modes
- Full Time 4 Wheel Drive
- Limited Slip Front Axle
- Three Gear Outer Planetary Hubs
- Adjustable Seat
- Full Instrumentation
- Road Lights
- Horn
- Backup Alarm
- Wet Disc Brakes
- Parking Brake
- Quick Fit Tool System
- Automatic Attachment Leveling
- Hydraulic Lock-out Valves
- Auxiliary Boom Hydraulics
- Left & Right Side Mirrors
- Front & Roof Windshield Wipers
- Front & Roof Sun Screen
- Front & Rear Work Lights
- Hood Screen Trash Shroud
- Neutral Start Switch
- Tow Pin

OPTIONAL EQUIPMENT:

- A wide variety of attachments and options are available to meet the customer's individual applications

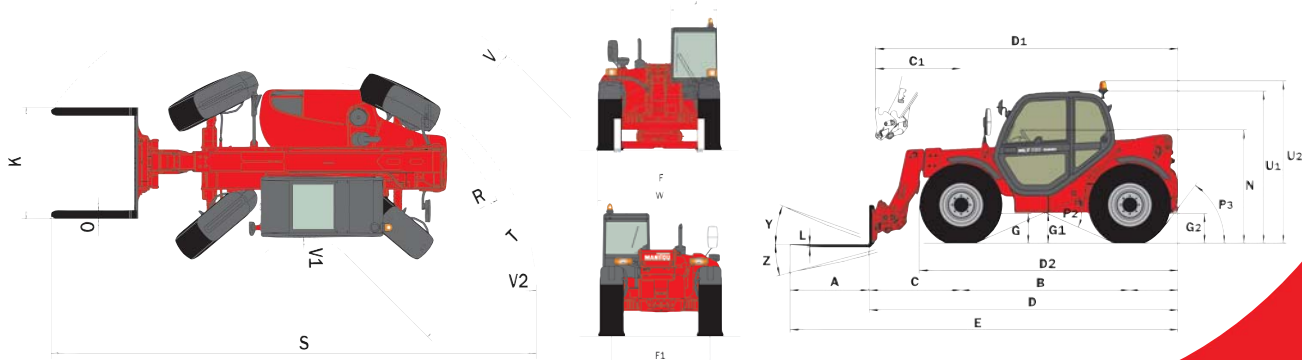

This publication in no way constitutes an offer and the company reserves the right to alter specification without prior notice. The MANITOU models presented in this brochure can be supplied complete with optional equipment attachments.

2/15/06 Printed in U.S.A.

MANITOU NORTH AMERICA, INC.
P.O. Box 21386
Waco, TX 76702-1386
Tel: 800-433-3304 Fax: 254-799-4433
www.manitou-na.com

